

ELECTRONIC TOTAL STATION SET4

OPERATOR'S MANUAL



LIETZ/SOKKISHA

CONTENTS

1. PARTS OF THE INSTRUMENT	1
2. FEATURES	4
3. SPECIFICATIONS	5
4. STANDARD EQUIPMENT	8
5. LIETZ SYSTEM S3 STREAMLINED SURVEYING SOLUTIONS	9
6. POWER SUPPLIES	14
7. DISPLAY SYMBOLS	16
8. KEY FUNCTIONS	17
9. INTERNAL SWITCHES	20
10. OPERATION	21
10.1 PREPARATION FOR ANGLE MEASUREMENT ..	21
10.1.1 Battery, No. 6651-01: Mounting and check ..	21
10.1.2 Compensation of zenith angle	22
10.1.3 Centering the SET4 by adjusting tripod leg length	23
10.1.4 Focusing	23
10.2 ANGLE MEASUREMENT	24
10.2.1 Automatically indexing vertical circle	24
10.2.2 Angle measurement	25
10.2.3 Setting the horizontal circle to a required value	26
10.2.4 Repetition of angles	27
10.3 PREPARATION FOR DISTANCE MEASUREMENT	29
10.3.1 Prism constant correction	29
10.3.2 Atmospheric correction	30
10.3.3 Earth-curvature and refraction correction	32
10.3.4 Prism sighting	33
10.3.5 Mode selection	34
10.4 DISTANCE MEASUREMENT	35
10.4.1 Angle and distance measurement	35
10.4.2 Remote elevation measurement	38
10.4.3 Measurement of horizontal distance between two target points	40
11. SELF DIAGNOSIS	41
12. ACCESSORIES	43
12.1 PRISMS	43
12.2 TRIBRACHS AND ADAPTORS	45
12.3 TARGETS	46

12.4 POLES	46
12.5 THERMOMETER AND ALTIMETER	47
12.6 DIAGONAL EYEPIECE	48
13. CHECKS AND ADJUSTMENTS	49
13.1 ANGLE MEASURING FUNCTION	49
13.1.1 Plate level	49
13.1.2 Circular level	51
13.1.3 Index error of the tilt angle sensor	51
13.1.4 Reticle	53
13.1.5 Perpendicularity of the reticle to the horizontal axis	56
13.1.6 Coincidence of the distance measuring axis with the reticle	57
13.1.7 Optical plummet	58
13.2 DISTANCE MEASURING FUNCTION	59
13.2.1 Check flow chart	59
13.2.2 Additive distance constant	60
14. FOR ANGLE MEASUREMENT OF THE HIGHEST ACCURACY	62
14.1 MANUALLY INDEXING VERTICAL CIRCLE BY V1, V2	62
15. FOR DISTANCE MEASUREMENT OF THE HIGHEST ACCURACY	64
15.1 ACCURACY OF MEASUREMENT OF ATMOSPHERIC CONDITIONS	64
15.2 TO OBTAIN THE ATMOSPHERIC PRESSURE	64
16. PRECAUTIONS AND MAINTENANCE	66
16.1 PRECAUTIONS	66
16.2 MAINTENANCE	67
17. ATMOSPHERIC CORRECTION CHARTS	68
18. INDEX	70

1. PARTS OF THE INSTRUMENT

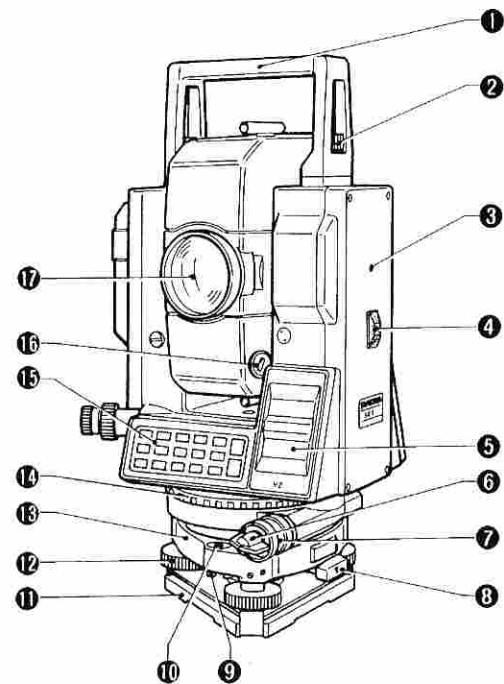
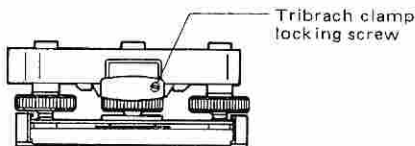

Fig. 1.1

- | | |
|----------------------------------|--------------------------------------|
| ① Handle | ⑩ Circular level |
| ② Handle securing screw | ⑪ Base plate |
| ③ Instrument height mark | ⑫ Leveling foot screw |
| ④ Internal switch cover | ⑬ Tribrach |
| ⑤ Display | ⑭ Horizontal circle positioning ring |
| ⑥ Lower clamp | ⑮ Keyboard |
| ⑦ Lower clamp cover | ⑯ Prism constant switch cover |
| ⑧ Tribrach clamp | ⑰ Objective lens |
| ⑨ Circular level adjusting screw | |



IMPORTANT

When the new SET4 is shipped, the tribrach clamp is fixed with a screw. Loosen it and leave it loose.

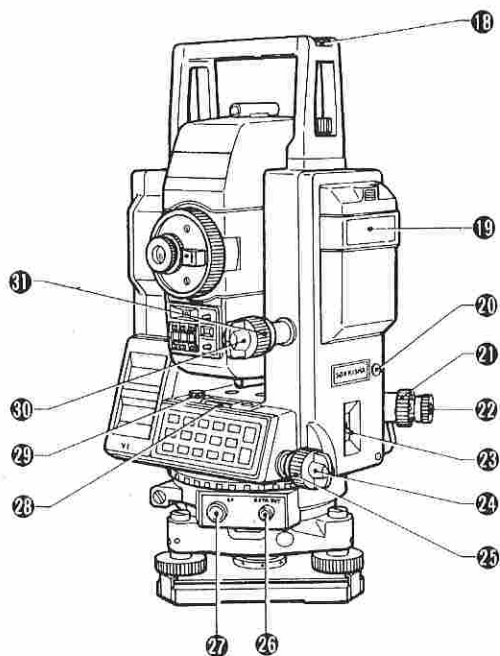

Fig. 1.2

- | | |
|----------------------------------|------------------------------------|
| 18 Tubular compass slot | 25 Horizontal fine motion screw |
| 19 Battery | 26 Data output connector |
| 20 Sensor index adjustment cover | 27 External power source connector |
| 21 Optical plummet focusing ring | 28 Plate level |
| 22 Optical plummet eyepiece | 29 Plate level adjusting screw |
| 23 Power switch | 30 Vertical clamp |
| 24 Horizontal clamp | 31 Vertical fine motion screw |

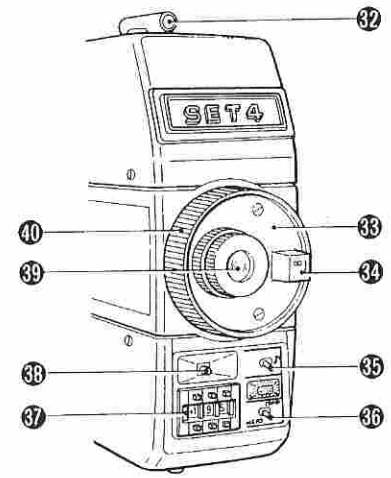

Fig. 1.3

- | | |
|---------------------------------|-----------------------------|
| 32 Peep sight | 36 Measure/track switch |
| 33 Telescope reticle adjustment | 37 Ppm switch |
| 34 Telescope plunging knob | 38 Return signal lamp cover |
| 35 Return signal audio switch | 39 Telescope eyepiece |
| | 40 Telescope focusing ring |

2. FEATURES

- Horizontal angle, zenith angle, slope distance, horizontal distance, height difference are displayed by key operation.
- Horizontal distance between two prism points and remote measurement of objects above and below a prism point are automatically calculated.
- Self-diagnostic function. If, for any reason, the SET4 is not functioning correctly during use, an error code is displayed.
- The tilt angle of the vertical axis can be measured by the internal sensor and displayed. By referring to the display, the SET4 can be leveled. The zenith angle is automatically compensated by the tilt sensor and the compensated angle displayed.
- Horizontal circle can be set to zero in any direction.
- The SET4 automatically switches off 30 minutes after the last operation to save battery power.
- A RS-232C data-out connector is standard.
- Measured data can be collected and stored by using a data collector.
- Measured data can be transmitted to an external device by pressing **REC** key on the keyboard.

3. SPECIFICATIONS

Distance measurement

Range: (When using LIETZ standard reflecting prisms)

Average conditions: (Slight haze, visibility about 12.5 miles, sunny periods, weak scintillation)

1-prism 3,300 ft (1,000 m)

3-prism 5,300 ft (1,600 m)

Good conditions: (No haze, visibility about 25 miles, overcast, no scintillation)

1-prism 4,300 ft (1,300 m)

3-prism 6,900 ft (2,100 m)

Standard deviation: $\pm(5 \text{ mm} + 3 \text{ ppm} \cdot D)$

Display: LCD 8-digit four display windows, two on each face

Maximum slope distance
6,561.67 ft (1,999.999 m)

Minimum display: MEAS. 0.01 ft (1 mm)

TRACK. 0.1 ft (10 mm)

Measuring time:

	Mode	
	MEAS.	TRACK.
Slope distance		
Horizontal distance	6 s + every 4 s	6 s + every 0.4 s
Height difference		
Remote elevation	1 s + every 0.5 s	
Horizontal distance between two points	8 s + every 4 s	8 s + every 1 s

Atmospheric correction: -99 ppm to +199 ppm
(1 ppm per step)

Prism constant correction: 0 to -9 cm (1 cm per step)

Earth-curvature and refraction correction: Selectable ON/OFF

Audio target acquisition: Selectable ON/OFF

Signal source: Infrared LED

Light intensity control: Automatic

Angle measurement

Telescope

Length: 6.7 inch (170 mm)
Aperture: 1.8 inch (45 mm)
Magnification: 30x
Resolving power: 3"
Image: Erect
Field of view: 1°30' (26 ft/1,000 ft)
Minimum focus: 4.3 ft (1.3 m)

Horizontal circle

Type: Incremental
Minimum display: 5"

Vertical circle

Type: Incremental with 0 index
Minimum display: 5"

Accuracy

Standard deviation of mean of measurement taken in positions V1 and V2 (DIN18723)

H: 5"
V: 5"

Automatic compensator

Type: Selectable ON/OFF
Liquid
Minimum display: 5"
Range of compensation: $\pm 3'$

Display

Range: $-1,999^{\circ}59'55''$ to $1,999^{\circ}59'55''$

Measuring mode

Horizontal angle: Right/Left/Repetition of angles
Vertical angle: Zenith 0° or Horizontal 0° or Horizontal $0^{\circ} \pm 90^{\circ}$
Measuring time: Less than 0.5 s

Sensitivity of levels

Plate level: 30"/2 mm
Circular level: 10'/2 mm

Optical plummet

Image: Erect
Magnification: 3x
Minimum focus: 0.3 ft (0.1 m)

Data output:

Asynchronous serial, RS-232C compatible

Self-diagnostic function:

Provided

Power saving cut off:

30 minutes after operation

Operating temperature:

-4°F to $+122^{\circ}\text{F}$ (-20°C to $+50^{\circ}\text{C}$)

Power source:

Ni-Cd battery, No. 6651-01 (6V)

Working duration:

About 600 measurements at 77°F , distance and angle measurement; 13 hours at 77°F , angle measurement only.

(About 4,000 measurements, distance and angle measurement; 90 hours at 77°F , angle measurement only, with optional battery No. 6661-02.)

Charging time:

12 hours, standard charger No. 6855-01
(1 hour, optional charger No. 6855-02, No. 6855-03)

Instrument height:

9.29 inch (236 mm)

Size (without handle):

6.6 (W) x 6.7 (D) x 13.0 (H) inch
(168 x 170 x 330 mm)

Weight:

16.7 lbs (7.6 kg) (w/internal battery)

4. STANDARD EQUIPMENT

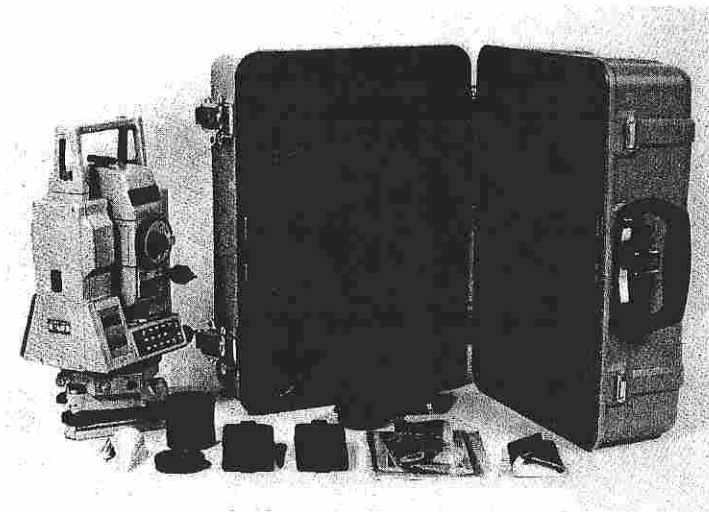

Fig. 4.1

SET4 main unit	1	Tool pouch	1
Internal battery, No. 6651-01	2	Screwdriver	1
Battery charger, No. 6855-01	1	Lens brush	1
Battery charging adaptor, No. 6660-00	1	Adjusting pin	2
Tubular compass, CP7 (accuracy: $\pm 1^\circ$)	1	Cleaning cloth	1
Lens cap	1	Atmospheric correction chart	1
Lens hood	1	Operator's manual	1
Vinyl cover	1	Field guide	1
		Carrying case, SC46	1

5. LIETZ SYSTEM S3 STREAMLINED SURVEYING SOLUTIONS

The complete, proven system for field measurement, data collection, data processing, printing and plotting.

Start an all day job and finish before noon?

When you work with the Lietz System S3, you'll find yourself doing just that. This proven field-to-office connection doubles your productivity and at the same time, actually improves your accuracy.

Using S3 components, you can be twice as competitive on every job. Twice as profitable.

One sighting with a SET Total Station gives you simultaneous distance and angle measurements. This data is then fed into the SDR2 Electronic Field Book directly and accurately without the need for handwritten notes.

From here, data can be electronically transmitted into Lietz Coordinate Geometry Plus™ surveying software on your IBM-PC/XT or AT.

You and your Lietz System S3 can do it all with a minimum amount of training and with virtual elimination of human error.

The Lietz nationwide organization of more than 50 Systems Centers backs System S3 to give you all the training, service and software support you need. The Lietz Warranty insures your satisfaction. Leasing plans are also available from your local Authorized Distributor.

THE LIETZ SYSTEM S3

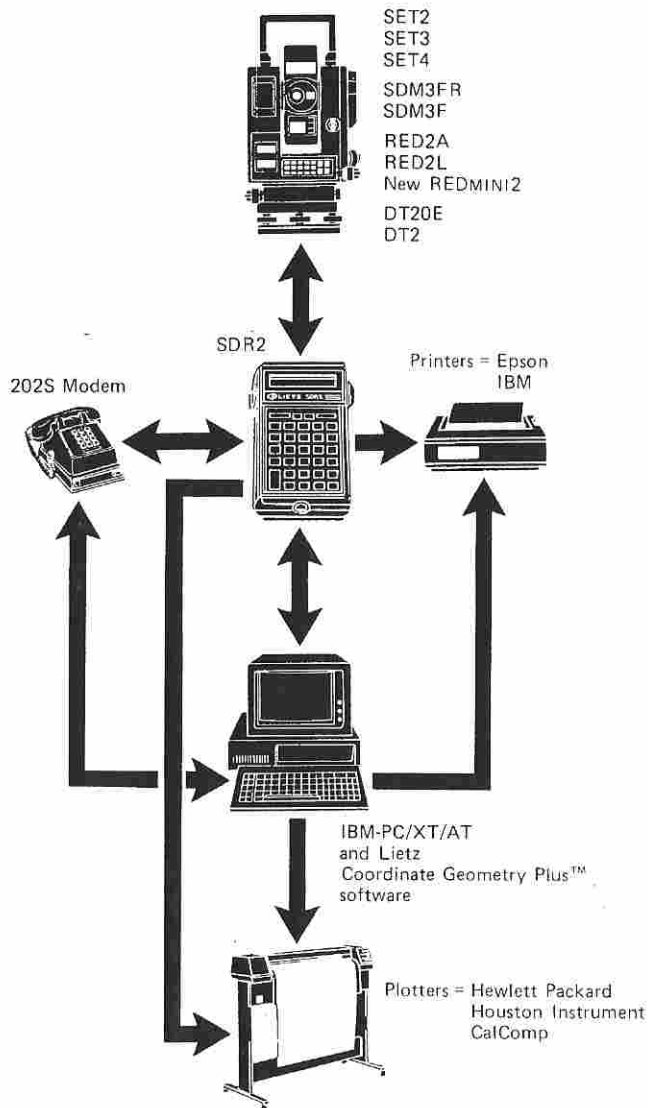

Fig. 5.1

Coordinate Geometry Plus is versatile and has the ability to run on either floppy disk or hard disk IBM units. It has been designed to run on the IBM-PC, XT, or AT. Listed below are the hardware requirements for these three.

RECOMMENDED STANDARD CONFIGURATIONS FOR IBM-PC, XT AND AT MICROCOMPUTERS

Configuration #1

IBM-PC with Epson Dot-matrix printer

- 1 - IBM #5150176 IBM-PC w/dual disk drives, 256K memory
- 1 - IBM #1504910 Color graphics board
- 1 - IBM #5153001 Color screen
- 1 - IBM #1502074 IBM Serial Port (25 pin)
- 1 - IBM #1505200 Parallel Port
- 1 - EPSON FX-85 + Epson dot-matrix printer (160 cps, 80 columns)

Configuration #2

IBM-XT with Epson Dot-matrix printer

- 1 - IBM #5160086 IBM-XT hard disk w/1-disk drive*
- 1 - IBM #1504910 Color graphics board
- 1 - IBM #5153001 Color screen
- 1 - IBM #1505200 Parallel port
- 1 - IBM #1502074 IBM Serial Port (25 pin)
- 1 - EPSON FX-85 + Epson dot-matrix printer (160 cps, 80 columns)

Configuration #3

IBM-AT (Enhanced) with Epson Dot-matrix printer

- 1 - IBM #5170079 IBM-AT (Enhanced)*
- 1 - IBM #1504910 Color graphics board
- 1 - IBM #5153001 Color screen

- 1 - IBM #1502074 IBM Serial Port (25 pin)
- 1 - EPSON FX-85 + Epson dot-matrix printer (160 cps, 80 columns)

* Additional 360K Disk Drive recommended.

Note: When ordering, it is necessary to state which hardware configuration you are using.

Lietz No. 5110-01 Coordinate Geometry Plus™ program consisting of Traverse, Coordinate Geometry, Figure, Geometric Solutions. Includes Least Squares and Celestial Observation subroutines.

Lietz No. 5110-10 Plotting Routine for Houston Instruments DMP42/52.

Lietz No. 5110-12 Plotting Routine for Hewlett Packard 7580 Series.

Lietz No. 5110-15 Plotting Routine for Calcomp 945/965/1043.

Lietz No. 5110-05 SDR2 Data Transfer (optional)

Lietz No. 5120-00 Lietz CONTOUR PLUS™ (optional)

Lietz No. 5310-03 SDR2 Tracking (optional)

Note: Lietz guarantees your satisfaction with Coordinate Geometry Plus software. If, for any reason, you return CGP within 30 days of receipt, you will be given a full refund.



Fig. 5.2 5300-17

202S MODEM

Universal Data Systems 202S LP Modem for use with SDR2 Electronic Field Book.

Note: SDR2 must be used with 202S modem to allow acoustic transmissions.

Lietz No. 5300-17

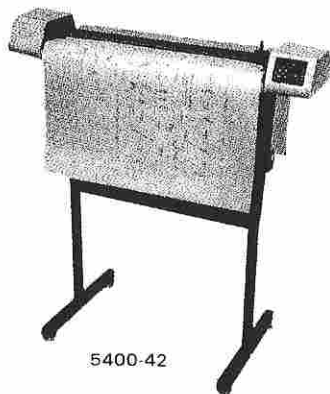

Fig. 5.3

PLOTTERS

Houston Instrument plotters are designed to meet the needs of the professional user: lightweight, easy to operate, accurate, and affordable. With the combination of robust drives and optimized pen ballistics you can create plots of high precision.

DMP42

Paper size: 18" x 24" (C)
24" x 36" (D)

Step size resolution: 0.005"
Speed: 3 ips axial, 4.2 ips diagonal
Lietz No. 5400-42

DMP52

Paper size same as DMP42
Step size resolution: .001", .005"
Speed: 16 ips axial, 22 ips diagonal
Lietz No. 5400-52

CALCOMP PLOTTER

Built to rigorous standards, the CalComp eight-pen plotter is designed to meet the demanding requirements of surveying, engineering, and construction applications. Choose from "A" to "D" size plots, multiple pen colors and types, and a variety of media, including paper and film. The 1043GT plotter guides you through operation procedures and identifies errors. Self-diagnostics built-in to the 1043GT run tests every time the plotter is turned on. The control panel display notifies you if further attention is required.

Operation is simple with CalComp's intelligent control panel. Color coded function keys allow communication of basic instructions and provide tactile feedback on commands entered. The 40-character alphanumeric display and concise keyboard design prompt the operator through setup procedures; the display contrast adjusts for easy readability.

1043GT

Paper size: 18" x 24" (C)
24" x 36" (D)
Step size resolution: .001", .005"
Speed: 1g; 14 ips
Lietz No. 5400-94

SDR2 ELECTRONIC FIELD BOOK

The SDR2 collects and stores slope distance, zenith and horizontal angle data from the SET. Calculations can be performed on the data so that the measurements can be verified in the field. The stored data can be transmitted to a data processing system.

Lietz No. 5300-02 SDR2 Electronic Field Book (32K) (1100 Coordinate Sets) w/RS232 interface and cable w/instrument connector, DB25 printer adapter (5300-08), Applications Guide, Getting Started Guide and carrying case.

Lietz No. 5300-00 SDR2 Electronic Field Book (16K) (500 Coordinate Sets) complete with same equipment as 5300-02.

Lietz No. 5279-01 Y-Interface to combine the data outputs of the RED2A, RED2L, RED2 and DT20E.

Lietz No. 5300-10 SDR2 Tripod bracket (right hand) for Lietz No. 7512-52 tripods.

Lietz No. 5300-11 SDR2 Tripod bracket (left hand) for Lietz No. 7512-52 tripods.

Lietz No. 5300-17 Universal Data Systems 202S LP modem for use with SDR2.

Lietz No. 5310-01 SDR2 Plotting program.

Lietz No. 5310-02 "New Topography" program.

Lietz No. 5310-03 SDR2 Tracking Program.

Note: All items backed by Lietz Systems and a one-year warranty.

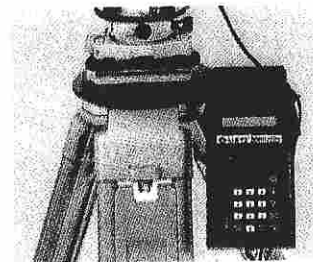

Fig. 5.4

MOUNTING BRACKET

Fits on Lietz No. 7512-52 Tripods and holds SDR2 (or any hand-held calculator) in such a way that it rotates with the instrument for convenient and easy operation. Available in right hand or left hand configurations.

HP-IL INTERFACE FOR THE HP41 OR HP71B

Attaches in seconds to your HP41 or HP71 Series hand-held calculator and allows complete interfacing with your Lietz Total Station.

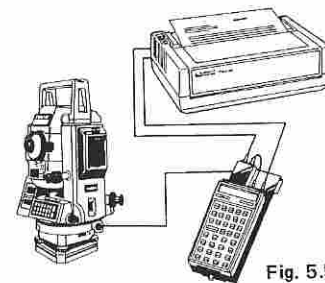

Fig. 5.5

Lietz No. 5275-02 IL Connection for HP71B including carrying case and instruction manual.

Lietz No. 5275-03 IL Connection for HP41 Series including carrying case and instruction manual.

6. POWER SUPPLIES

The SET4 can be operated with the following combinations:

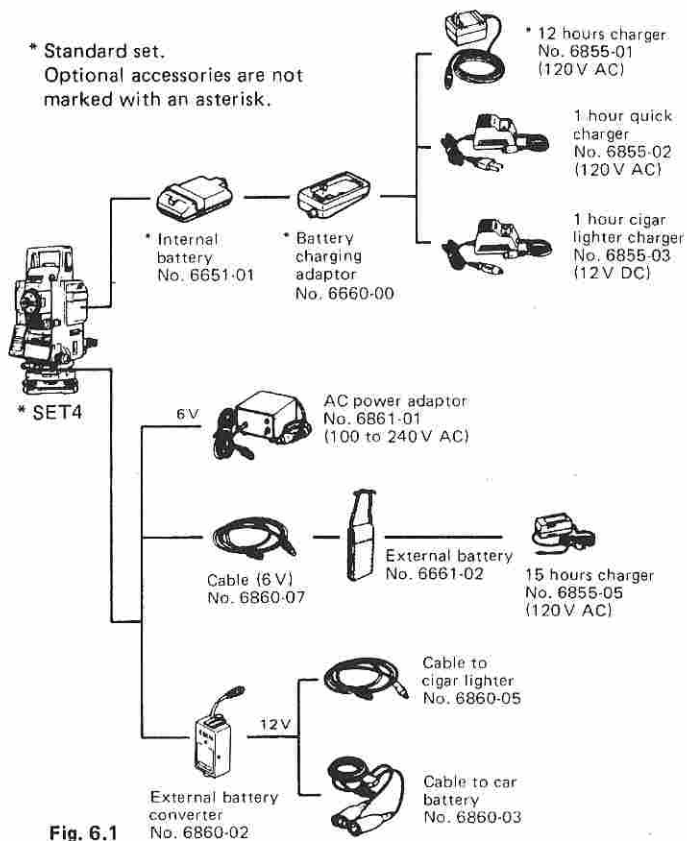

Use the SET4 only with the combinations shown here.

Note: When using the SET4 with external power supplies, it is recommended that for the most accurate angle measurements, the No. 6651-01 battery be left in place to balance the weight on the axes.

Battery charging precautions

To charge the battery, use only the recommended charger.

- 1) Charge the battery at least once a month if it is not used for a long time.
- 2) Charge the battery at a temperature between 50°F to 104°F (10°C to 40°C).
- 3) Before using No. 6861-01, set the voltage selector to the proper voltage.
- 4) No. 6860-02 has a breaker switch. Normally the red mark appears on the breaker. If not, set the red mark in place.
- 5) When using a car battery, make sure that the polarity is correct.
- 6) Make sure that the cigar lighter has 12V output and that the negative terminal is grounded.
- 7) When charging the battery, first connect it to the battery charger and then connect the charger to the power supply. Check that the battery charger light is on. If not switch power supply off and on again until the light comes on.
- 8) The battery charger may become warm while charging. This is normal.
- 9) Do not charge the battery for any longer than specified.
- 10) Store the battery in a place where the temperature is between 32°F to 104°F (0°C to 40°C).
- 11) Battery operating life is shortened at extreme temperatures.

7. DISPLAY SYMBOLS

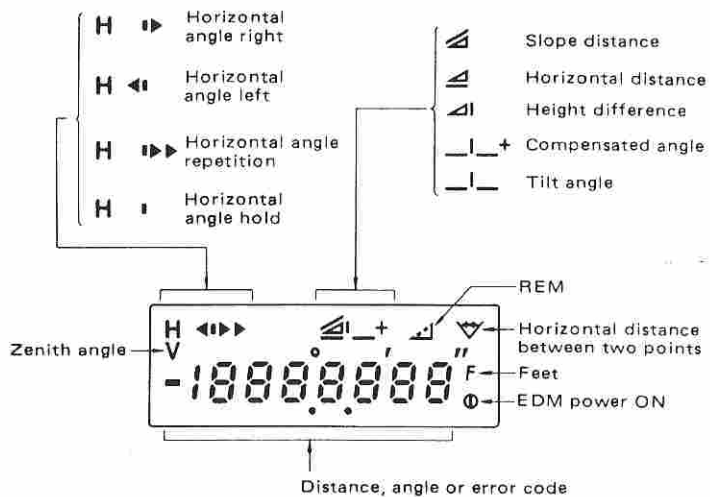

Fig. 7.1

8. KEY FUNCTIONS

SET4 has three measurement modes. When it is switched on and the vertical circle is indexed by rotating the telescope, it is automatically in the theodolite mode.

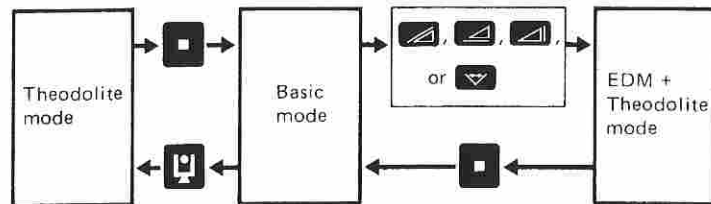

Fig. 8.1

Theodolite mode

Angle measurement.

SET4 accepts [Square Key], [0], [◊], [M], [◀▶], [▶▶], [⏻], [SET] or [REC] keys.

Basic mode

Prism sighting and recall.

SET4 accepts all keys except [Square Key], [M], [◀▶], [▶▶] or [SET] keys.

EDM + Theodolite mode

Angle and distance measurement.

SET4 accepts [Square Key] or [◊] keys.

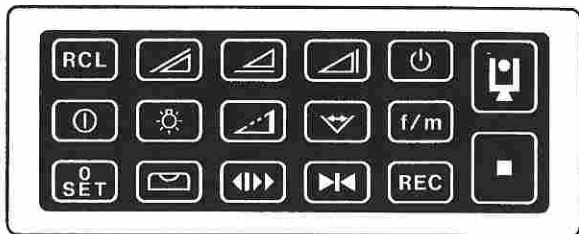

























Fig. 8.2

-  • Select theodolite mode.
-  • Stop measurement and transfer to basic mode.
-  • Recall data from memory.
-  • Measure slope distance.
-  • Measure horizontal distance.
-  • Measure height difference.
-  • EDM power ON/OFF for locating prism.
-  • Illuminate display and reticle of telescope for 30 seconds.

-  • Measure remote elevation.
 -  • Measure horizontal distance between two prism points.
 -  • Convert displayed distance to feet or meters for 5 seconds.
 -  • Display vertical axis tilt angle ON/OFF.
 -  • Select horizontal angle to left, right or by repetition (accumulation).
 -  • Hold/release horizontal angle.
 -  • Required before using  or .
 -  • Set horizontal angle to zero by pressing  then .
 -  • Transfer data to an external device by pressing  then .
- (If  is pressed without connecting with a computer, error indication "E209" is displayed. This key is not available for the SDR2.)

9. INTERNAL SWITCHES

Switches are located under internal switch cover ④.

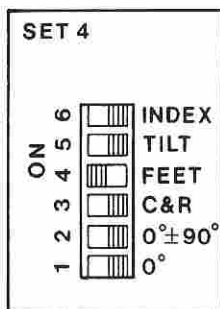

Fig. 9.1

Switch	Function	
6	ON	Manually index vertical circle by V1, V2
	* OFF	Automatically index vertical circle by transiting telescope
5	ON	Vertical circle compensator off
	* OFF	Vertical circle compensator on
4	* ON	Display distance in feet
	OFF	Display distance in meters
3	ON	Distance corrected for earth-curvature and refraction
	* OFF	Distance not corrected for earth-curvature and refraction
2	ON	Display vertical angle with 0° horizontal ±90°
	* OFF	Vertical angle display controlled by switch 1
1	ON	Display vertical angle with 0° horizontal on face V1
	* OFF	Display zenith angle

(The asterisk indicates the position of each switch at the time of shipping.)

- Before changing switch settings, turn power switch OFF.

10. OPERATION

10.1 PREPARATION FOR ANGLE MEASUREMENT

10.1.1 Battery, No. 6651-01: Mounting and check

- 1) Confirm that the power switch ② is OFF.
- 2) Mount the battery No. 6651-01 in the SET4.
Hold the left standard when inserting the battery. Push it until a click is heard to indicate correct location. Confirm that the battery is fixed securely.

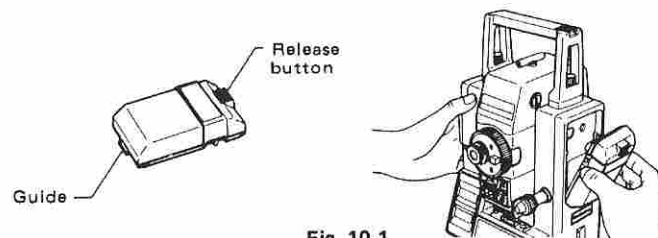

Fig. 10.1

- (To remove the battery, turn the power switch OFF and push down the release button of the battery.)
- 3) Two short audio signals are heard when the power is switched ON. The display shown in ① and then ② indicate the instrument is in normal condition.

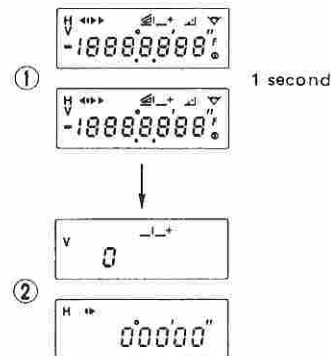

Fig. 10.2

If the battery voltage is too low, the display will appear as shown below. Set the power switch OFF and replace the battery with a charged one, or charge the battery.

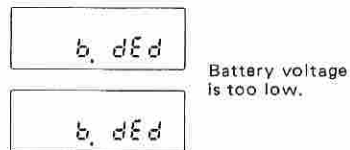

Fig. 10.3

10.1.2 Compensation of zenith angle

- 1) Remove the switch cover ④.
- 2) To use zenith angle with compensation, set switch 5 to OFF with a screw driver. (The factory setting is OFF.)
- 3) Replace the cover.

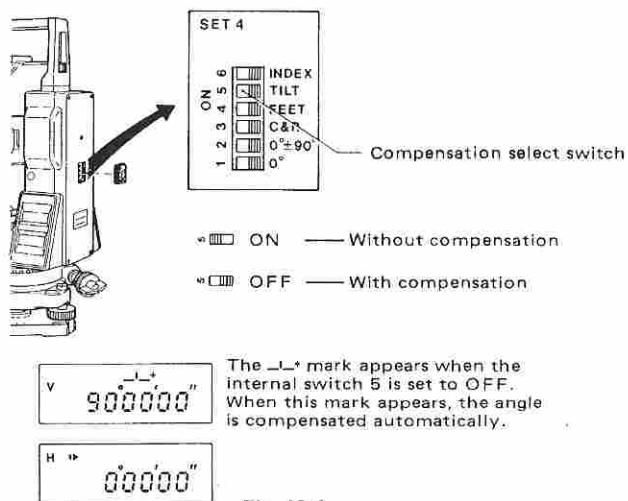

Fig. 10.4

The internal tilt sensor has a range of $\pm 3'$ and a resolution of $5''$. Read the automatically compensated zenith angle when the display is steady. When the display is not steady due to vibration or strong wind, set switch 5 to ON to use the SET4 without compensation.

10.1.3 Centering the SET4 by adjusting tripod leg length

- 1) Make sure that:
 - a. The tripod head is approximately level.
 - b. The tripod shoes are firmly fixed in the ground.
- 2) Set the SET4 on the tripod head. Tighten the centering screw.
- 3) Focus on the surveying point:
 - a. Turn the optical plummet eyepiece ⑳ to focus on the reticle.
 - b. Turn the optical plummet focusing ring ㉑ to focus on the surveying point.
- 4) Turn the leveling foot screws ㉒ to center the surveying point in the reticle.
- 5) Observe the off-center direction of the bubble in the circular level ㉓. Shorten the leg nearest that direction, or extend the leg farthest from that direction. Generally, two legs must be adjusted to center the bubble.
- 6) When centering of the circular level is completed, turn the leveling screws to center the plate level ㉔ bubble.
- 7) Look through the optical plummet again. If the surveying point is off-center, loosen the centering screw to center the surveying point on the reticle. Tighten the centering screw.
- 8) Repeat 6), 7) if the plate level bubble is off-center.

10.1.4 Focusing

- 1) Looking through the telescope, turn the eyepiece fully clockwise, then anticlockwise until just before the reticle image becomes blurred. In this way, frequent refocusing can be dispensed with, since your eye is focused at infinity.
- 2) Loosen the vertical ㉕ and horizontal clamp ㉖. Bring the target into the field of view with the peep sight ㉗. Tighten both clamps.
- 3) Turn the focusing ring ㉘ and focus on the target. Sight the target with the vertical ㉙ and horizontal fine motion screws ㉚. Focus on the target until there is no parallax between the target and the reticle.

Parallax:

Relative displacement of target image in respect to the reticle when observer's head is moved slightly before the eyepiece.

If sighting is carried out before parallax is eliminated, this will introduce errors in reading and will impair your observations.

10.2 ANGLE MEASUREMENT

Make sure that:

- The SET4 is set up correctly over the surveying point.
- Battery voltage is adequate.

10.2.1 Automatically indexing vertical circle

- Turn the power switch  ON.

Make sure that the display appears as shown below.

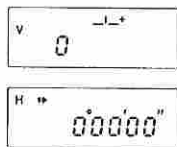



Fig. 10.5

- Loosen the vertical clamp , and use the telescope plunging knob  to rotate the telescope completely.

(Indexing occurs when the objective lens crosses the horizontal plane in position V1.)

When the vertical circle is indexed, an audio signal is given and the display appears as below.

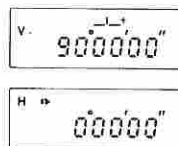



Fig. 10.6

Angle measurement can now begin.

Note: When the power switch is turned off for any reason, the vertical index is lost. When the power switch is turned back on, the vertical index must be redetermined.

10.2.2 Angle measurement

Before this procedure, index the vertical circle.

- Select theodolite mode by pressing .
- Select the horizontal angle right or left with  according to measuring method.

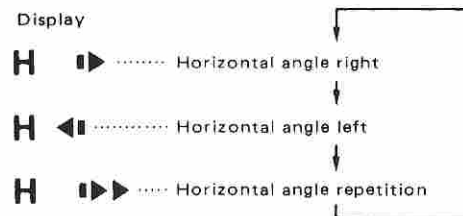

Fig. 10.7

When  is pressed, the display changes alternately as shown in Fig. 10.7.

- Sight the first target A.
- Press  then  to set the horizontal angle display to 0°.

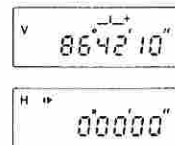

Fig. 10.8

- 5) Use the horizontal clamp ④ and the vertical clamp ⑩ to sight the second target B.

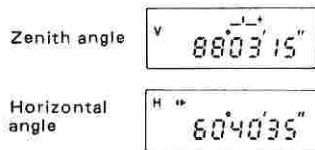

Fig. 10.9

The displayed horizontal angle is the angle between targets A and B.

10.2.3 Setting the horizontal circle to a required value

To set the horizontal circle to the reference target, for example $90^{\circ}10'20''$:

- 1) Loosen the horizontal clamp ④ and the lower clamp ⑥ and hold the upper alidade lightly. Turn the circle positioning ring ① until the display becomes about 90° and tighten both clamps. Turn the horizontal fine motion screw ⑤ until the desired angle is displayed.

Note: When using the lower clamp ⑥, push the cover ⑦.

- 2) Press \blacktriangleleft .

H \blacksquare Horizontal angle
hold display

Fig. 10.10

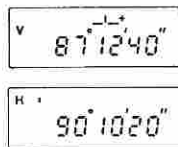

Fig. 10.11

- 3) Turn the instrument and sight the target.
- 4) Press \blacktriangleright to release the display hold.
The required horizontal circle value is now set to the reference target.

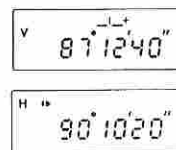

Fig. 10.12

10.2.4 Repetition of angles

Repetition of angles from $-1,999^{\circ}59'55''$ to $1,999^{\circ}59'55''$ is displayed by using \blacktriangleleft .

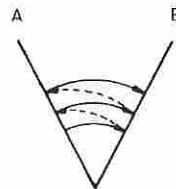

Fig. 10.13

- 1) Press \blacktriangleleft to select repetition of angle.

H \blacktriangleleft Repetition of angle
display

Fig. 10.14

- 2) Sight target A, and press \blacksquare then SET .

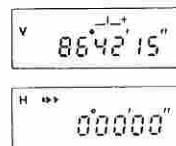

Fig. 10.15

- 3) Use the horizontal clamp **(4)** and the horizontal fine motion screw **(5)** to sight target B.

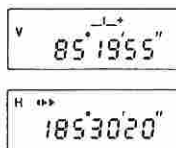

Fig. 10.16

- 4) Press **(F4)** to hold the horizontal angle display.
 5) Use the lower clamp **(6)** and the horizontal fine motion screw **(5)** to turn back to target A.

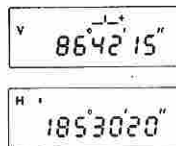

Fig. 10.17

- 6) Press **(F4)** to release the display hold.
 7) Use the horizontal clamp and the horizontal fine motion screw to sight target B.

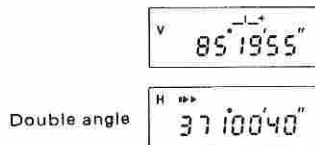

Fig. 10.18

- 8) Repeat 4) to 7) steps to measure repetition of angles.
 9) To release the repetition of angle display, press **(F5)**.

10.3 PREPARATION FOR DISTANCE MEASUREMENT

10.3.1 Prism constant correction

- 1) Remove the prism constant switch cover **(16)** with a coin.
- 2) Use the screwdriver to turn the prism constant setter to match the reflecting prism constant correction value.
 i.e. For a prism constant correction value of -3 cm, set the index to 3 (-3 cm).

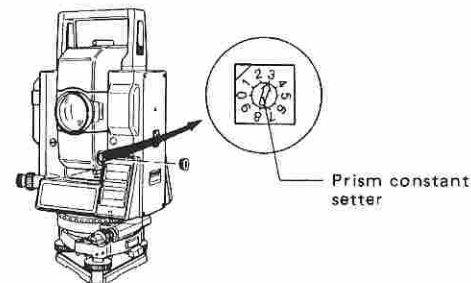

Fig. 10.19A

- 3) Replace the cover.

Prism constant values of Sokkisha reflecting prisms.

The prism constant of the AP series prisms is 30 mm (the same value as the previous Sokkisha prism) using the prism spacer AP01S (standard accessory). The constant can be changed to 40 mm by removing the prism spacer.

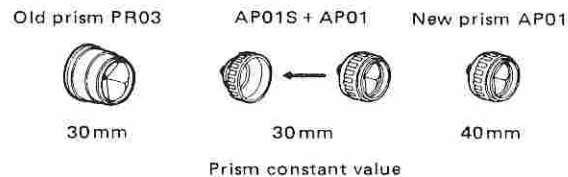

Fig. 10.19B

When using reflecting prisms with constant values other than the above, a prism constant correction of 0 cm to -9 cm can be set in steps of 1 cm using the prism constant setter.

10.3.2 Atmospheric correction

The SET4 is designed so that the correction factor is 0 for a temperature of +59°F (+15°C) and an atmospheric pressure of 29.9 inchHg (760 mmHg). The correction factor is obtained from the pressure and temperature as follows.

- 1) Measure the temperature and atmospheric pressure with a thermometer and a barometer.

Pressure can be obtained from weather station sea level data by correcting for altitude. For altitude correction see 15.2.

- To convert millibars to inchHg multiply by 0.0295.
- To convert mmHg to inchHg divided by 25.4.
- To convert temperature from Centigrade to Fahrenheit, use the formula:

$$^{\circ}\text{F} = \frac{9}{5}^{\circ}\text{C} + 32$$

- 2) Read the correction factor from the atmospheric correction table on pages 68 and 69.

Example: Temperature +77°F (+25°C)
 Atmospheric pressure 29.5 inchHg (750 mmHg)
 Correction factor is +13 ppm.

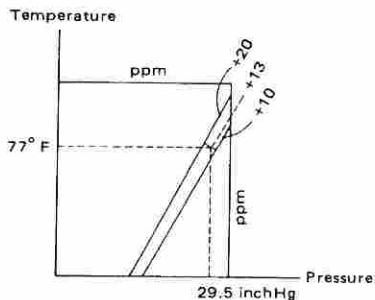

Fig. 10.20

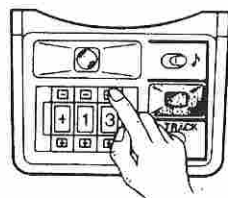

Fig. 10.21

- 3) Set the ppm switch **37** to +13.

- 4) To obtain the atmospheric correction factor by computation.

- a. inchHg — °F system (English):

Atmospheric correction factor

$$X = 278.96 - \frac{10.5 \times P}{1 + 0.002175 \times t}$$

P: Atmospheric pressure in inchHg

t: Temperature in Fahrenheit

Example: P = 29 inchHg, t = +60°F

$$\text{ppm} = 278.96 - \frac{10.5 \times 29}{1 + 0.002175 \times 60} = 9.61 \approx 10$$

Set the ppm switch to +10.

- b. mmHg — °C system (Metric):

Atmospheric correction factor

$$X = 278.96 - \frac{0.3872 \times P}{1 + 0.003661 \times t}$$

P: Atmospheric pressure in mmHg

t: Temperature in Centigrade

- 5) For slope distances equal to or more than 6,561.68 ft (2,000.000 m) (exceeding the maximum display 6,561.67 ft (1,999.999 m)), the ppm switch should be set to 0 and the corrected slope distance calculated by the formula:

$$D = (6,561.68 + d) \times \left(1 + \frac{X}{1,000,000}\right)$$

D: Corrected slope distance

d: The display of slope distance when ppm is set to 0

X: Correction factor in ppm

Example: Slope distance 6,594.48 ft (displayed as 32.80 ft)

X = +5 ppm

$$D = (6,561.68 + 32.80) \times \left(1 + \frac{5}{1,000,000}\right) = 6,594.51 \text{ ft}$$

10.3.3 Earth-curvature and refraction correction

- 1) Remove the internal switch cover ④.
- 2) To correct horizontal distance and height difference for earth-curvature and refraction, set switch 3 to ON with a screw-driver.
- 3) Replace the cover.

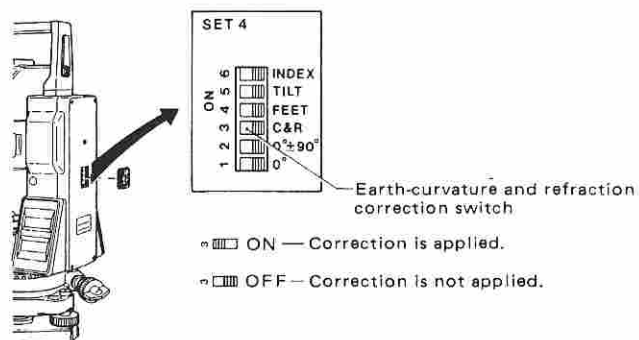

Fig. 10.22

- This correction is performed in the measurement of horizontal distance and height difference. The value displayed by the SET4 is computed by the following formula:

When the switch is ON

Horizontal distance after correction

$$H' = S \times \sin Z - \frac{1 - K}{2R} \times S^2 \times \sin Z \times \cos Z$$

Height difference after correction

$$V' = S \times \cos Z + \frac{1 - K}{2R} \times S^2 \times \sin^2 Z$$

When the switch is OFF

$$\text{Horizontal distance} \quad H = S \times \sin Z$$

$$\text{Height difference} \quad V = S \times \cos Z$$

S: Slope distance (value after atmospheric correction)

Z: Zenith angle

K: Atmospheric refraction constant (0.142)

R: Radius of the earth (2.09×10^7 ft)

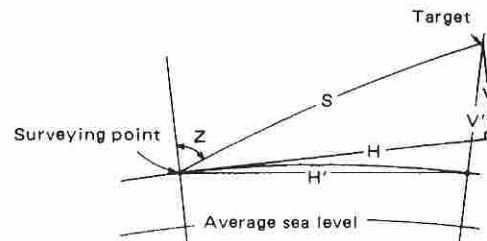

Fig. 10.23

Example: Amount of correction for a zenith angle of 70°

S (ft)	500	1,500	3,000	5,000
H' - H (ft)	-0.00	-0.03	-0.13	-0.36
V' - V (ft)	0.00	0.04	0.16	0.45

Note that the horizontal distance is a distance measured at the height of the surveying point above the sea level. It is necessary to reduce this distance to the average sea level and to apply the local projection correction. Further, since the SET4 does not apply the earth-curvature and refraction and atmospheric corrections when a slope distance is more than 6,561.67 ft, such corrections should be performed by computation.

10.3.4 Prism sighting

- 1) Sight the center of the reflecting prism with the telescope.
 - 2) Set the return signal audio switch ⑤ to Δ .
 - 3) Set the power switch ⑧ to ON and press ⑩.
 - ⑩ turns the power supplied to the EDM unit ON or OFF. Usually the power of the EDM unit turns OFF automatically after 1 second of inactivity and the power source mark disappears.
 - But when ⑩ is pressed, power is supplied to the EDM unit for about 2 minutes to permit prism sighting.
- a. When power is supplied to the distance measurement unit (EDM unit), the power source mark ① is displayed.

- b. When the reflected light is received by the telescope, an audio signal is heard and the return signal lamp **38** lights up.

When the light intensity coming back from the prism is very high, the return signal lamp may light up, even for a slight mis-sighting. Make sure that the target center is sighted correctly.

- 4) Switch off the audio target acquisition.

10.3.5 Mode selection

- 1) Select the mode switch **36** to MEAS. for fine measurement, or TRACK. for tracking.

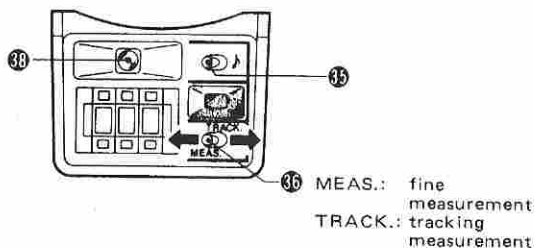

Fig. 10.24

MEAS.: Measures in hundredths of a foot, first after 6 to 8 seconds, then every 4 seconds.

TRACK.: Measures in tenths of a foot, first after 6 to 8 seconds, then every 0.4 to 1 second.

10.4 DISTANCE MEASUREMENT

Make sure that:

- The SET4 is set up correctly over the surveying point.
- The prism constant switch, the earth-curvature refraction switch, and ppm switch are set correctly.
- Battery voltage is adequate.
- Indexing the vertical circle is complete.

10.4.1 Angle and distance measurement

- 1) Press **■** to stop angle measurement.

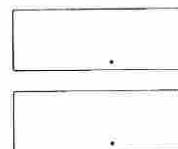

Fig. 10.25

- 2) Press **○** and sight the center of the reflecting prism. (See 10.3.4)

- 3) Press **▲** to measure slope distance. The following display appears showing that the slope distance measurement is being performed.

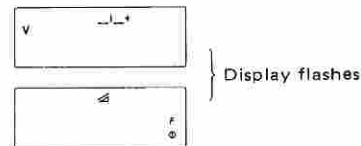

Fig. 10.26

- 4) The slope distance and the zenith angle will be displayed after about 6 seconds.

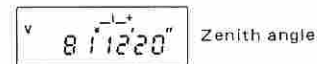



Fig. 10.27



Slope distance will continue to be measured every 4 seconds.

- Maximum display for slope distance is **6,561.67 ft (1,999.999 m)**. For longer slope distances, see 10.3.2.
- When the following keys are pressed instead of  in step 3), the measurement corresponding to each key is performed.

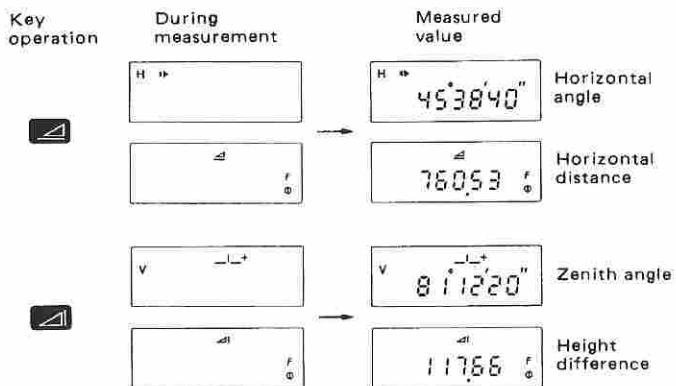



Fig. 10.28

- 5) Press  to stop measurement.

If it is necessary to convert displayed feet distance to metric, press . The metric value will be displayed for 5 seconds. If the usual measurement is in meters, the display will be changed temporarily to feet.

- 6) After stopping, you can recall the following observational data, which are stored in the instrument, by pressing the appropriate keys.

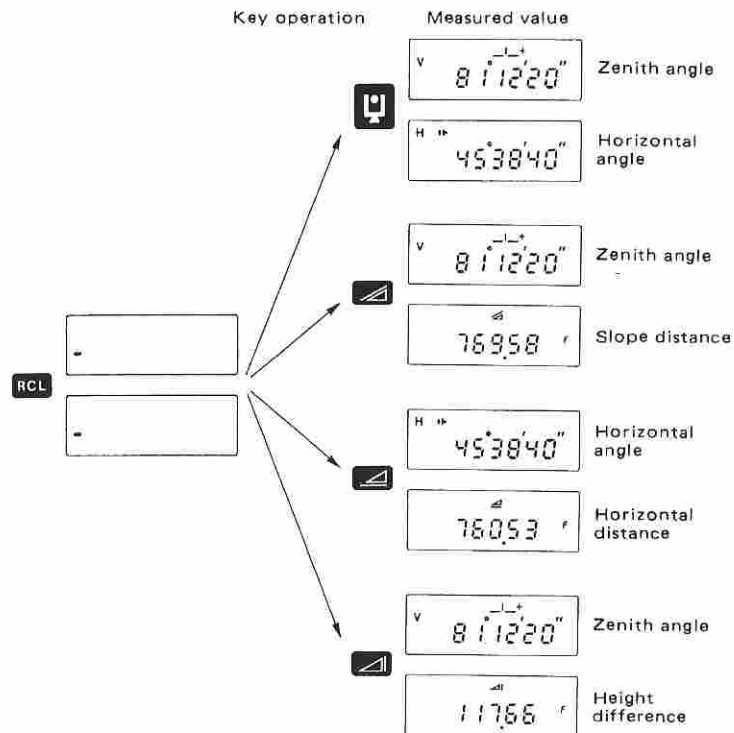



Fig. 10.29

- Each measured value displayed is the result obtained in the latest measurement.

- 7) To use as a theodolite after distance measurement, press  then .

10.4.2 Remote elevation measurement

At certain surveying points e.g. power transmission lines or cables supporting bridges, etc., a reflecting prism cannot usually be positioned. In such cases the remote elevation measurement makes height differences easy to measure.

$$h = S (\sin \theta_{Z1} \times \cot \theta_{Z2} - \cos \theta_{Z1})$$

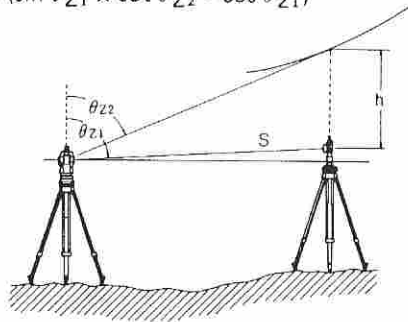

Fig. 10.30

- 1) Set up a reflecting prism under the object.
 - Use an optical plummet to set the prism accurately.
 - 2) Sight the reflecting prism and press .
- Press after the distance measurement data is displayed.

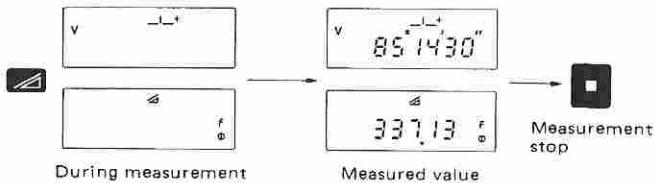

Fig. 10.31

- The measured value is stored in the SET4.

- 3) Sight the object and press . The object height from the prism, h, will be displayed in the lower display.

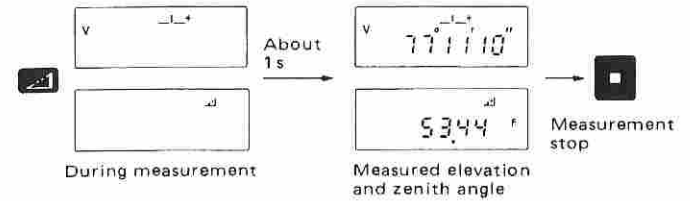

Fig. 10.32

- The range of measurement is between vertical angles of -89° and 89° .

10.4.3 Measurement of horizontal distance between two target points

Horizontal distance L and height difference H between two points can be measured.

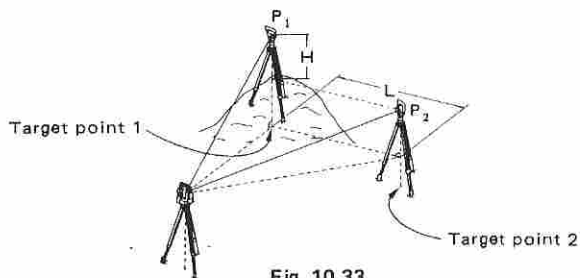

Fig. 10.33

- 1) Set up the reflecting prisms P_1, P_2 , on target points 1, 2.
- 2) Sight the prism P_1 and press

Press after the distance measurement data is displayed.

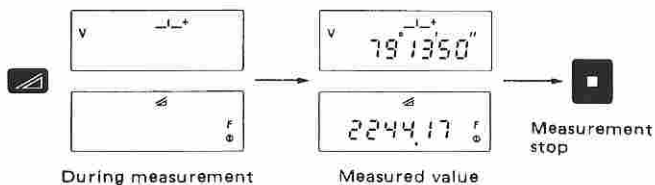

Fig. 10.34

- The measured value is stored in the SET4.

- 3) Sight the prism P_2 and press

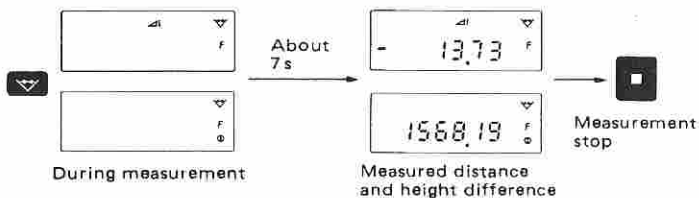

Fig. 10.35

11. SELF DIAGNOSIS

If there is any fault in the measuring function, the error codes shown in the following table will be displayed.

Display	Meaning	Action
b. dEd	Battery voltage is too low.	Replace the battery with a charged one, or charge the battery.
E 100	*Error when measuring a horizontal angle.	Reset to the horizontal angle 0° (0 gon).
E 101	*Error when measuring a zenith angle.	Index the vertical circle again.
E 115	Compensator range error. Tilt angle exceeds $-3'$.	Level the SET4 again.
E 117	Compensator range error. Tilt angle exceeds $+3'$.	
E 200	Incoming reflected light decreased during measurement. Incoming reflection was disturbed.	Sight the reflecting prism again. Increase the number of reflecting prisms for long distances. Measure the distance again confirming the condition with the return signal lamp or sound.
S. OFF E 201	Incoming reflection is totally absent when the instrument is ready for distance measuring.	

Display	Meaning	Action
E 206	Error when measuring the initial slope distance during either remote elevation or horizontal distance measurement between two points measurement.	Sight the reflecting prism to perform slope distance measurement again.
E 207	During remote elevation measurement, the vertical angle is more than $\pm 89^\circ$ or the measured distance is more than $\pm 9,999.999$ m.	Press ■ to stop measuring.
E 208	The measured distance is more than $\pm 19,999.99$ ft ($\pm 19,999.999$ m).	Press ■ to stop measuring.
E 209	Communication error between the SET4 and an external device when pressing REC .	Change measurement mode.

* If the SET4 is rotated faster than four revolutions per second, the error indication "E100" or "E101" is displayed.

When the error indication "E" appears with any number other than the ones above, please contact our agent.

12. ACCESSORIES

12.1 PRISMS

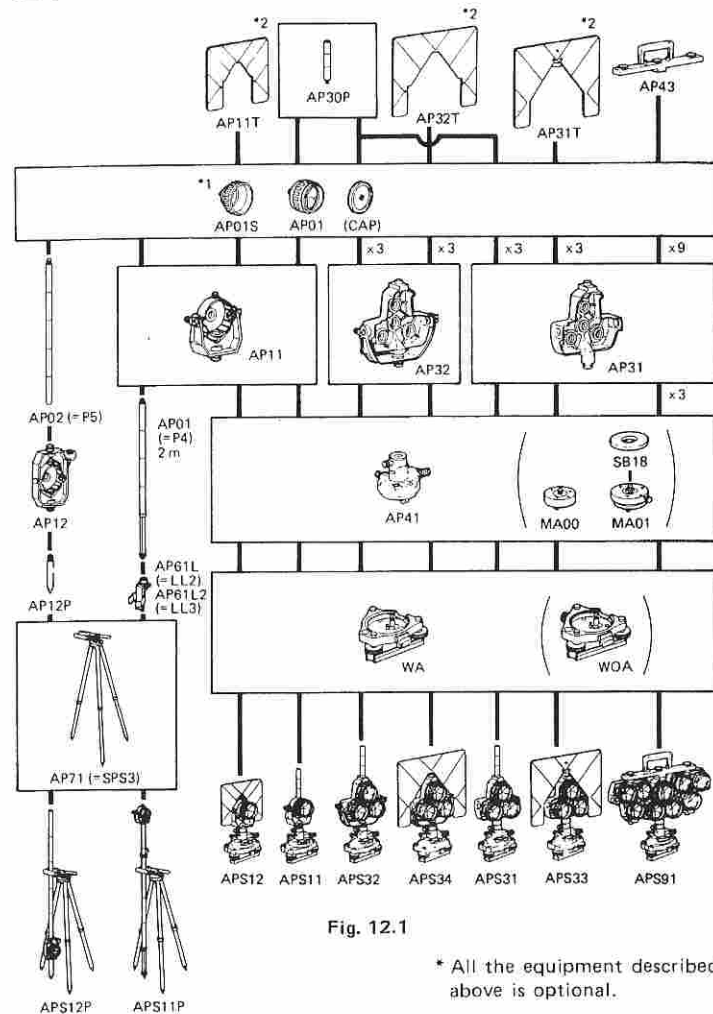

Fig. 12.1

* All the equipment described above is optional.

*1: See 10.3.1 Prism constant correction.

*2: Fluorescent paint finishing allows clearer sighting in adverse observing conditions.

Precautions

- 1) Carefully face the reflecting prism towards the instrument; sight the target center accurately.
- 2) To use the triple prism assembly AP31 or AP32 as a single prism (e.g. for short distances), mount the single prism AP01 in the center hole of the triple prism holder.
- 3) Check that "236" (the height of the SET4) is displayed in the window of the instrument height adaptor AP41. The height of the AP41 can be adjusted as follows:
 - ① Loosen the two fixing screws.
 - ② Turn the center part counterclockwise to unlock it.
 - ③ Move it up or down until "236" appears in the window.
 - ④ Turn the center part clockwise to re-lock it.
 - ⑤ Tighten the fixing screws.

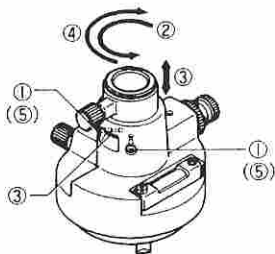

Fig. 12.2

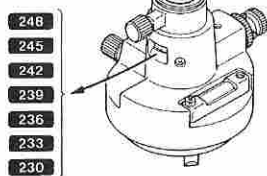

Fig. 12.3

- 4) Use the plate level on the AP41 to adjust the tribrach circular level as in 13.1.2.
- 5) Check the optical plummet of the AP41 as in 13.1.3. After all checks and adjustments have been completed, make sure that the AP41 optical plummet sights the same point as the optical plummet of the SET4.

12.2 TRIBRACHS AND ADAPTORS

OPTICAL PLUMMET TRIBRACH

For precision plumbing. Has circular level vial with sensitivity of 10 minutes per 2 mm. Optical plummet focus by push-pull slide. Range: 1.5 to 50 ft. No. 7311-35

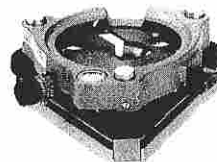

Fig. 12.4

TRIBRACH LEVELING BASE

Same as above but without optical plummet. For use with Azimuth Base (7150-41). No. 7311-34

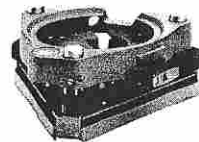

Fig. 12.5

TRIBRACH ADAPTOR

Allows installation of retro prism or other accessories into tribrach. 5/8 x 11 thread. No. 7311-37



Fig. 12.6

TRIBRACH ADAPTOR

Similar to above except with removable, rotatable center. No. 7311-38



Fig. 12.7

TRIBRACH ADAPTOR

Allows easy mounting of 7266-31 and other prism with bayonet type mount in tribrachs. No. 7311-40

OPTICAL PLUMMET TRIBRACH ADAPTOR

Similar to above but with rotating vertical axis and optical plummet for precise positioning of prisms in tribrachs without optical plummet. No. 7311-41

12.3 TARGETS

TRAVERSE SET

WITH CARRYING CASE. For precise triangulation surveys, day or night.

No. 7312-45 Set contains two each of the following:

7311-35 Optical Plummet Tribrachs

7311-37 Tribrach adaptors

7312-39 Illumination units

7312-40 Rotatable sighting targets mounted on a base

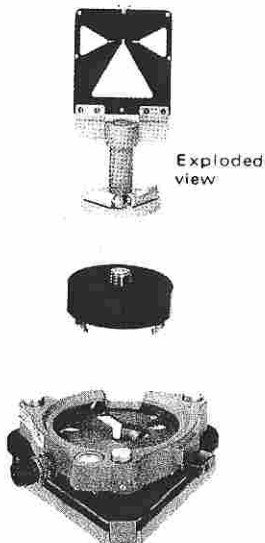

Exploded view

Fig. 12.8

LARGE TARGET

Large target 8-1/4" x 11-3/4" attaches to regular target (No. 7312-40) to provide increased sighting range.

No. 7312-42

12.4 POLES

RANGE PLUMBING POLE

Aluminum tubing and brass fittings with hardened steel point. Height adjusts from 54" to 100". Upper section mounting stud accepts single or triple retro prisms; locking disc prevents prism rotation. Includes replaceable rod level (No. 8071-90). No. 7270-48



Fig. 12.9

TELESCOPING RANGE PLUMBING POLE

Ideal for EDM and traverse work. Made of quality aluminum tubing with brass fittings and hardened steel point. Positive chuck style twist lock permits height adjustment from 54" to 100". Replaceable rod level (No. 8071-90) and point (No. 8078-50). Upper section has 5/8 x 11 mounting stud to accept single or triple retro prisms.

No. 7270-46



Fig. 12.10

TRIPODS

Tripods recommended for use with these accessories (not included in price):

No. 7512-52 Wide Frame,

Extension Leg (wood)

No. 7536-75 Wide Frame,

Extension Leg (aluminum)

RANGE POLE SUPPORT

Made with metal center castings, rustproof steel legs w/one adjustable (hinged) leg for uneven ground. No. 8078-90

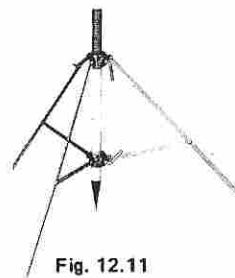

Fig. 12.11

RANGE POLE TRIPOD

Heavy-duty. Made with metal center castings. Rustproof steel legs, adjustable for uneven ground. No. 8078-95

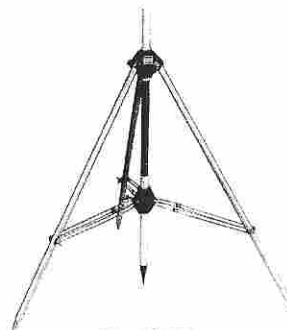

Fig. 12.12

12.5 THERMOMETER AND ALTIMETER

POCKET THERMOMETER

Refillable metal case. Mercury filled. Range: -30° to 120°F in 2° increments.

No. 8006-12



Fig. 12.13

BAROMETER/ALTIMETER

with watch-type case. English-Range 0 to 15,000 ft. No. 8001-70



Fig. 12.14

12.6 DIAGONAL EYEPIECE

The diagonal eyepiece is convenient for steep observations and in places where space around the instrument is limited.

Remove the eyepiece ④ by loosening the mounting ring, and screw in the diagonal eyepiece.

Setting up the 7311-18

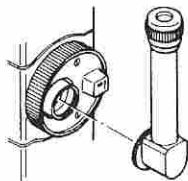

Fig. 12.15

13. CHECKS AND ADJUSTMENTS

The SET4 may be affected by sudden changes in weather conditions and excessive vibration. This can result in inaccurate surveying. Therefore, IT IS IMPORTANT TO CHECK AND ADJUST THE SET4 BEFORE AND DURING USE in the following order.

13.1 ANGLE MEASURING FUNCTION

- 13.1.1 Plate level
- 13.1.2 Circular level
- 13.1.3 Index error of the tilt angle sensor
- 13.1.4 Reticle
- 13.1.5 Perpendicularity of the reticle to the horizontal axis
- 13.1.6 Coincidence of the distance measuring axis with the reticle
- 13.1.7 Optical plummet

13.1.1 Plate level

The glass tube of the plate level is sensitive to temperature change or shock. Be sure to check the plate level ④ before use.

- 1) See Figs. 13.1 and 13.2 for relation between bubble movement and rotation of the leveling foot screws.

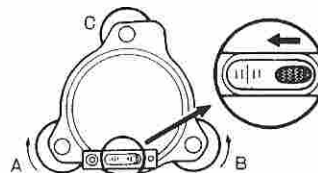

Fig. 13.1

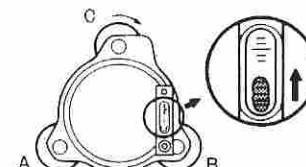

Fig. 13.2

- 2) Turn the upper part of the SET4 until the plate level is perpendicular to a line between leveling screws A and B. Then center the bubble using the leveling screw C.

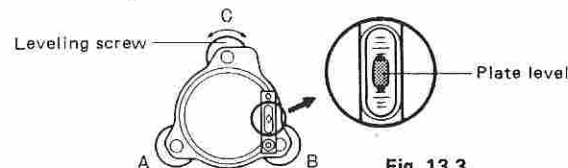

Fig. 13.3

- 3) Turn the upper part 90° until the plate level is parallel to the line between leveling screws A and B. Then center the bubble by turning leveling screws A and B by the same amount and in the opposite direction.

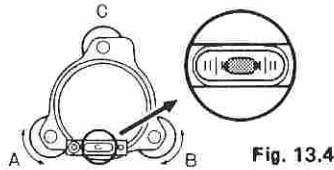

Fig. 13.4

- 4) Turn the upper part 180° . Correct the bubble deviation, if any, by half the amount with leveling screws A and B, as in 3) above.

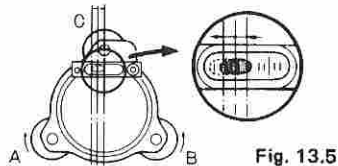

Fig. 13.5

- 5) Correct the remaining half deviation by turning the plate level adjusting screw ⑨ with the adjusting pin.

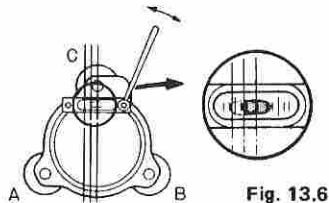

Fig. 13.6

- 6) Repeat 2) to 5) above until the bubble remains centered for all the positions of the upper part.

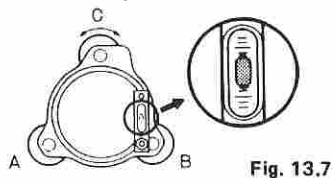

Fig. 13.7

13.1.2 Circular level

When the plate level adjustment is complete, the circular level ⑩ should be checked. Note the direction off-center of the bubble. Loosen the adjusting screw ⑨ farthest from that direction and tighten the other adjusting screws to center the bubble.

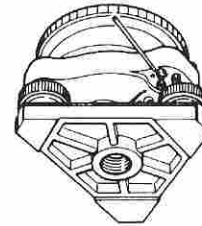

Fig. 13.8

13.1.3 Index error of the tilt angle sensor

When the circular level adjustment is complete, the index error should be checked.

- 1) After indexing the vertical circle, tighten the vertical clamp ⑩.
- 2) Press ON then SET to set the horizontal circle to zero, then press OFF to display the tilt angle.



Fig. 13.9

- 3) Loosen the horizontal clamp and turn the upper part through $180^\circ \pm 5'$.

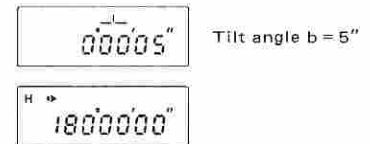

Fig. 13.10

4) Calculate $\frac{a+b}{2}$ = index error c

Example: $\frac{-10'' + 5''}{2} = -2.5''$

5) If the index error is less than 5'', no adjustment is necessary.

For adjustment remove the sensor index adjustment cover 20. Return to 0° horizontal angle position.

Using a suitable flat screwdriver, adjust the internal screw until the upper display $d_{0^\circ} = a - c$.

Turn the upper part through 180°.

Adjust the internal screw until the upper display $d_{180^\circ} = b - c$.

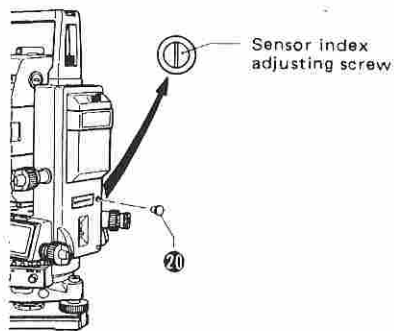

Fig. 13.11

Example:

If $a = -20''$, $b = -10''$, index error $c = \frac{-20'' + (-10'')}{2} = -15''$

$d_{0^\circ} = a - c = -5''$

$d_{180^\circ} = b - c = +5''$

13.1.4 Reticle

When the index error adjustment is complete, the position of the reticle should be checked.

1) Level the SET4. Select a clear target at a horizontal distance of 160 to 330 ft (50 to 100 m).

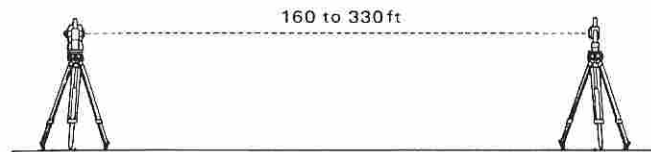

Fig. 13.12

2) After indexing the vertical circle, sight the target and take the horizontal angle reading in position V1, e.g. $a_l = 18^\circ 34' 00''$ and the zenith angle reading, e.g. $b_l = 90^\circ 30' 10''$.

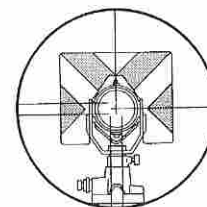

Fig. 13.13

3) Next in position V2, sight the same target. Take the horizontal angle reading, e.g. $a_r = 198^\circ 34' 10''$ and the zenith angle reading, e.g. $b_r = 269^\circ 30' 05''$.

4) Calculate $a_r - a_l$, $b_r + b_l$.

$a_r - a_l = 198^\circ 34' 10'' - 18^\circ 34' 00'' = 180^\circ 00' 10''$

$b_r + b_l = 269^\circ 30' 05'' + 90^\circ 30' 10'' = 360^\circ 00' 15''$

- 5) When the reticle is in the normal position, your results should show that $a_r - a_l$ is within 20" of 180° and $b_r + b_l$ is within 20" of 360° . If the difference of $a_r - a_l$ from 180° or $b_r + b_l$ from 360° is 20" or greater after several checks, adjust as follows.
- 6) While still in position V2, use the horizontal and vertical fine motion screws to adjust the lower display, a_c , and the upper display, b_c , to read:

$$a_c = \frac{a_l + a_r}{2} + 90^\circ$$

$$b_c = \frac{b_r - b_l}{2} + 180^\circ$$

Example:

$$\text{If } a_l = 18^\circ 34' 00'' \quad a_r = 198^\circ 34' 30''$$

$$b_l = 90^\circ 30' 10'' \quad b_r = 269^\circ 30' 20''$$

$$a_c = \frac{a_l + a_r}{2} + 90^\circ = \frac{18^\circ 34' 00'' + 198^\circ 34' 30''}{2} + 90^\circ = 198^\circ 34' 15''$$

$$b_c = \frac{b_r - b_l}{2} + 180^\circ = \frac{269^\circ 30' 20'' - 90^\circ 30' 10''}{2} + 180^\circ = 269^\circ 30' 05''$$

- 7) Look through the telescope. The target is seen shifted from the vertical and horizontal reticle lines.
- 8) Remove the reticle adjustment cover $\text{\textcircled{33}}$.

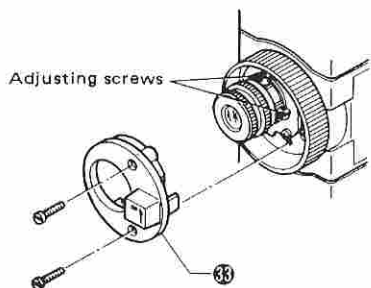

Fig. 13.14

- 9) Adjust the reticle sideways with the adjusting screws until the target is centrally within the vertical lines, and then adjust it up or down with the screws until the target is centrally within the horizontal lines.

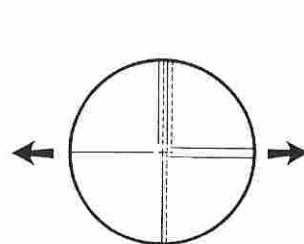

Fig. 13.15

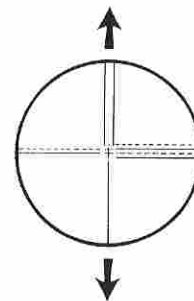

Fig. 13.16

- 10) Replace the cover.

The adjustment is very delicate. If it is difficult, please contact our agent.

N.B. If amount of the reticle shift is too large, distance measuring may be affected. Do not adjust the reticle more than 20".

13.1.5 Perpendicularity of the reticle to the horizontal axis

- 1) Select and sight a clear target on the upper part A of the vertical reticle line Fig. 13.17.
- 2) Turn the telescope slowly upward with the vertical fine motion screw ① until the target slides to the lower part B, Fig. 13.18. If the target is still centrally within the vertical lines no adjustment is necessary. If necessary, adjust as follows.

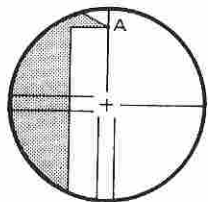

Fig. 13.17

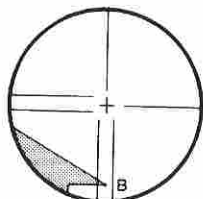

Fig. 13.18

- 3) If the target at B is not on the reticle, rotate the reticle plate by loosening the four adjusting screws.



Fig. 13.19

13.1.6 Coincidence of the distance measuring axis with the reticle

After the reticle has been checked, check the distance measuring axis relative to the reticle as follows.

- 1) Level the SET4. Set up the reflecting prism at a horizontal distance of 160 to 330 ft (50 to 100 m).

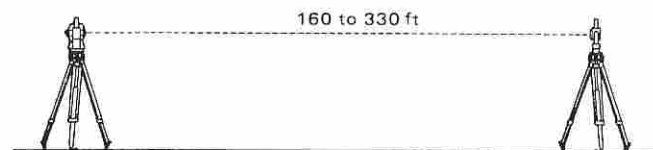

Fig. 13.20

- 2) Sight the reflecting prism center and take the horizontal and zenith angle readings. (H and Z respectively)

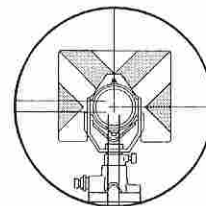

Fig. 13.21

- 3) Press Ⓞ on the keyboard and make sure the return signal lamp Ⓢ lights up.
- 4) Four more readings are necessary. Turn the horizontal or vertical fine motion screw slowly until the return signal lamp goes off. Then take readings.
Readings H_l, H_r : when the telescope is directed to the left (right) of the sighted direction in 2) above.
Readings Z_a, Z_b : when the telescope is directed above (below) the sighted direction in 2) above.
- 5) Check the differences of H_l (H_r) against H , and Z_a (Z_b) against Z .
When the four differences obtained are larger than $3'$, the coincidence is normal. If any of the differences obtained are less than $3'$, please contact an authorized service facility for repair.

13.1.7 Optical plummet

- 1) Level the SET4. Center a surveying point in the reticle of the optical plummet. Loosen the horizontal clamp and turn the upper part through 180°. If the surveying point is still centered, no adjustment is necessary.
- 2) If the surveying point is off-center, correct half the deviation with the four adjusting screws, and correct the remaining half with the leveling screws.

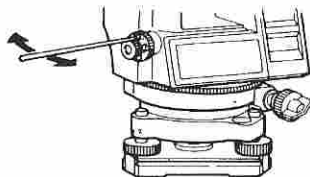

Fig. 13.22

- 3) Repeat the adjustment if necessary.

13.2 DISTANCE MEASURING FUNCTION

13.2.1 Check flow chart

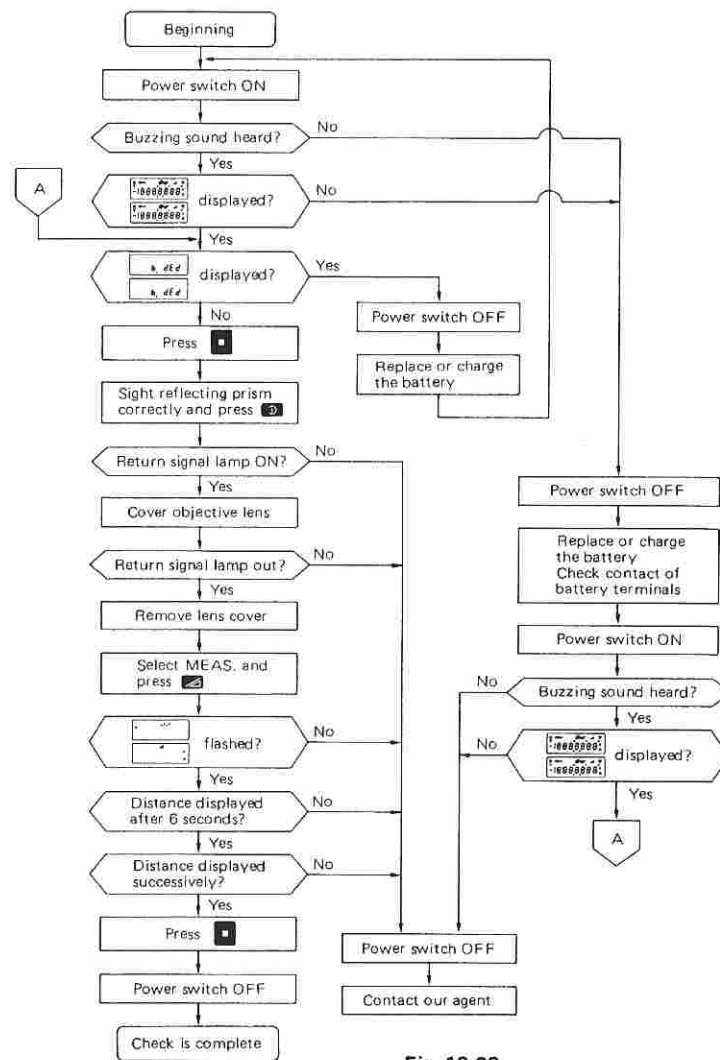

Fig. 13.23

13.2.2 Additive distance constant

The additive distance constant of the SET4 is adjusted to 0 before delivery. However, the additive constant can change with time and so should be determined periodically and then used to correct distances measured.

1) Determining the additive distance constant.

The most reliable method of determining the additive distance constant is to test the SET4 on an established base line with a maximum range of approximately 1,000 m, and with 6 to 8 intermediate stations spaced at multiples of the instrument unit length, which is 10 m. Measurements should be taken in all combinations of the 6 to 8 stations.

If an additive distance constant of greater than 5 mm is found please contact our agent.

2) Confirmation of the additive distance constant K if a base line is not available.

- a. Select points A and B on flat ground about 100 m apart, and C in the middle.
- b. Set up the SET4 at A, and measure the distance AB.

Note: Be sure prism height is the same as the height of the SET4 objective lens center. If ground is not level, use an automatic level to set correct instrument heights of all points.

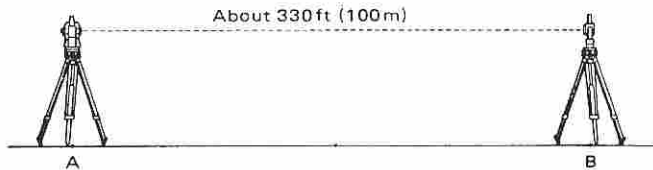

Fig. 13.24

- c. Shift the SET4 to C, and measure the distance CA and CB.

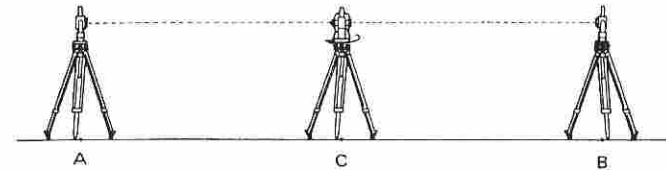

Fig. 13.25

- d. Compute the additive distance error K using the formula:

$$K = \overline{AB} - (\overline{CA} + \overline{CB})$$

\overline{AB} , \overline{CA} , \overline{CB} : Average of ten measurements.

- e. Obtain K value three times. If all K are greater than 5 mm, contact our agent.

14. FOR ANGLE MEASUREMENT OF THE HIGHEST ACCURACY

14.1 MANUALLY INDEXING VERTICAL CIRCLE BY V1, V2

Like every theodolite, the SET4 will have a vertical index error. A vertical index error can be estimated as follows.

- 1) Turn the power OFF, remove the internal switch cover **4** and set switch 6 to ON.

(When switch 6 is ON, the automatic indexing of the vertical circle by transitting the telescope is inactive.)

- 2) After leveling the SET4, turn the power ON and make sure that the display appears as shown below.

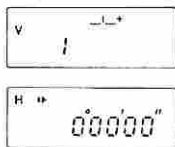

Fig. 14.1

- 3) In position V1, accurately sight a clear target at a horizontal distance of about 100 ft (30 m).

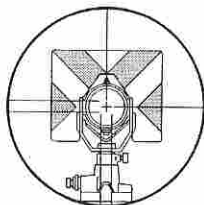

Fig. 14.2

- 4) Press **⏻** then **SET**.

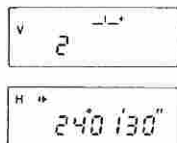

Fig. 14.3

- 5) Next in position V2, accurately sight the same target.

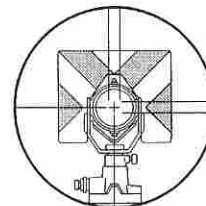

Fig. 14.4

- 6) Press **⏻** then **SET**. When the vertical circle is indexed, the display appears as below.

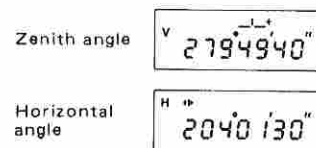

Fig. 14.5

- If the power switch has been turned OFF, the vertical circle must be indexed again. When moving the SET4 after measurement, turn the power OFF.

15. FOR DISTANCE MEASUREMENT OF THE HIGHEST ACCURACY

15.1 ACCURACY OF MEASUREMENT OF ATMOSPHERIC CONDITIONS

The relation between measured distance and the velocity of light is given by

$$D = \frac{T}{2} C = \frac{T}{2} \frac{C_0}{n}$$

T: The period between light emission and reception.

C: The velocity of light in the air.

C₀: The velocity of light in a vacuum.

n: Refractive index of the air.

The measured distance is affected by variation in the refractive index

$$\frac{dD}{D} = - \frac{dn}{n} \doteq dn \text{ (or } dD \doteq D \cdot dn)$$

Therefore, the accuracy of measurement of the refractive index must be the same as that of the measured distance.

To calculate refractive index to an accuracy of 2 ppm, temperature must be measured to within 2°F (1°C) and pressure to within 0.2 inchHg (5 mmHg).

15.2 TO OBTAIN THE ATMOSPHERIC PRESSURE

To obtain the average refractive index of the air throughout the measured light path, you should use the average atmospheric pressure.

If flat terrain there is little variation in the atmospheric pressure. In mountains, the following calculation should be used.

Example:

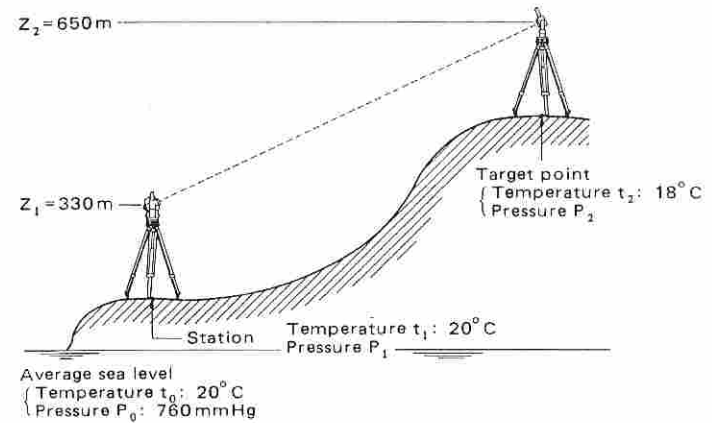

Fig. 15.1

By the Laplace formula

$$Z_n - Z_0 = 18,400 \left(1 + 0.00367 \frac{t_n + t_0}{2} \right) \text{Log} (P_0/P_n)$$

t: Temperature (°C)

Z: Height above sea level (m)

P: Pressure (mmHg)

$$P_n = 10^{\left\{ \text{Log } P_0 - \frac{Z_n - Z_0}{18,400 \left[1 + 0.00367 \left(\frac{t_n + t_0}{2} \right) \right]} \right\}}$$

$$P_0 = 760 \text{ mmHg} \quad Z_1 = 330 \text{ m} \quad Z_2 = 650 \text{ m}$$

$$t_0 = 20^\circ\text{C} \quad t_1 = 20^\circ\text{C} \quad t_2 = 18^\circ\text{C}$$

$$P_1 = 10^{\left\{ \text{Log } 760 - \frac{330}{18,400 (1 + 0.00367 \times 20)} \right\}} \doteq 731$$

$$P_2 = 10^{\left\{ \text{Log } 760 - \frac{650}{18,400 (1 + 0.00367 \times 19)} \right\}} \doteq 704$$

Average pressure: 717.5 mmHg

16. PRECAUTIONS AND MAINTENANCE

16.1 PRECAUTIONS

- 1) When the SET4 is not used for a long time, check it at least once every three months.
- 2) Handle the SET4 with care. Avoid heavy shocks or vibration.
- 3) If any trouble is found on the rotatable portion, screws or optical parts (e.g. lens), contact our agent.
- 4) When removing the SET4 from the carrying case, never pull it out by force. The empty carrying case should then be closed to exclude dust.
- 5) Never place the SET4 directly on the ground.
- 6) Never carry the SET4 on the tripod to another site.
- 7) Protect the SET4 with an umbrella against direct sunlight, rain and humidity.
- 8) When the operator leaves the SET4, the vinyl cover should be placed on the instrument.
- 9) Do not aim the telescope at the sun.
- 10) Always switch the power off before removing the internal battery.
- 11) Always remove the battery from the SET4 when returning it to the case.
- 12) Do not wipe the display **5**, keyboard **15** or the carrying case with an organic solvent.
- 13) When the SET4 is placed in the carrying case, follow the layout plan.
- 14) Make sure that the SET4 and the protective lining of the carrying case are dry before closing the case. The case is hermetically sealed and if moisture is trapped inside, damage to the instrument could occur.

16.2 MAINTENANCE

- 1) Wipe off moisture completely if the instrument gets wet during survey work.
- 2) Always clean the instrument before returning it to the case.

The lens requires special care. Dust it off with the lens brush first, to remove minute particles. Then, after providing a little condensation by breathing on the lens, wipe it with soft clean cloth or lens tissue.

- 3) Store the SET4 in a dry room where the temperature remains fairly constant.
- 4) If the battery is discharged excessively, its life may be shortened. Store it in a charged state.
- 5) Check the tripod for loose fit and loose screws.

17. ATMOSPHERIC CORRECTION CHARTS

(English)

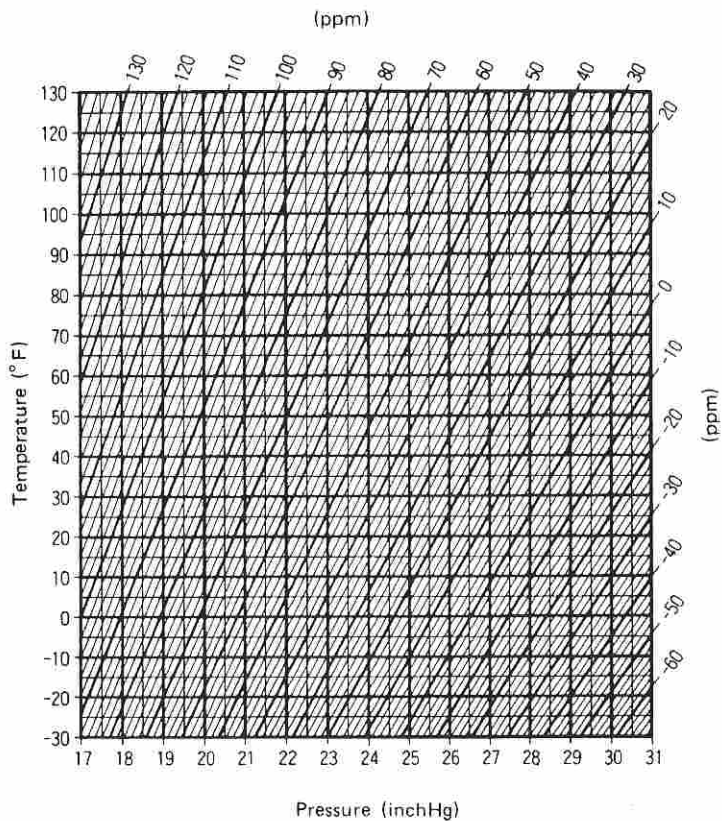

The chart shows the correction every two ppm, while the atmospheric correction can be applied to the SET4 for every ppm.

(Metric)

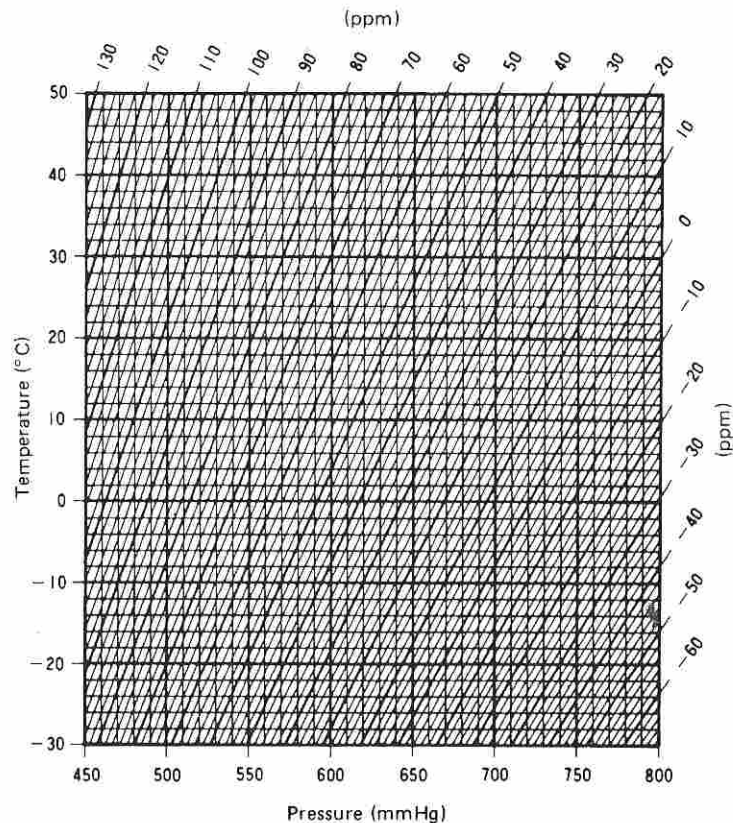

The chart shows the correction every two ppm, while the atmospheric correction can be applied to the SET4 for every ppm.

The specifications and general appearance of the instrument may be altered at any time and may differ from those appearing in catalogues and the operator's manual.

18. INDEX

	Page
Accessories	9, 14, 43
Angle measurement	24
Angle measurement modes	25
Atmospheric correction	30
Audio switch	33
Batteries	14
Circular level adjustment	51
Curvature and refraction correction	32
Display limit	31
Display symbols	16
Distance measuring axis checking	57
Distance measurement	35
Distance measurement checking	60
Distance measurement flow chart	59
Error codes	41
Features	4
Focusing	23
Horizontal distance between two points	40
Indexing manually	62
Instrument part names	1
Keyboard functions	17
Maintenance	67
Optical plummet adjustment	58
Parallax	24
Parts per million	31
Plate level adjustment	49
Power supplies	14
Powering up the SET4	21
Precautions	66
Prism constant	29
Recalling data	37
Remote elevation measurement	38

	Page
Repetition of angle	27
Reticle adjustment	53
Right and left angles	25
Setting up over a point	23
Specifications	5
Standard equipment	8
Switches, internal	20
Tilt angle sensor adjustment	51
Tracking mode	34
Zenith angle compensation	22