



SHC6400 is locked up or frozen

Troubleshooting a controller that is locked up or become frozen.

Five Second Shut Down



If the SHC6400 will not respond and you cannot get to the start menu.

- Press and Hold the Power Button  down for five seconds until the message “Slide to shutdown your PC” appears.
- Swipe to the bottom of the screen to power off the tablet.
- To power the tablet back on, press the Power Button  .





Ten Second Shutdown

If the SHC6400 has been locked up for at least 5 minutes and did not respond to the 5 second shutdown.

- Disconnect the SHC6400 from all external power sources, including the AC wall charger, a USB-C charger, or dock.
- To shut down press and hold the Power Button  for 10 seconds.
- To power the tablet back on press the Power Button .



Ten Second Shutdown

- If the SHC6400 has been locked up for at least 5 minutes and did not respond to the 10 second shutdown.
- Press and Hold the power Button  down for 20 seconds.
- The removable and internal batteries are electrically disconnected from the controller, causing a complete shutdown.
- To power on the controller and connect the batteries, plug in the controller with the AC wall Charger or a USB-C charger and press the power button  .
- **Caution:** Power off the controller by holding the power button for 10 or 20 seconds is a last resort. Forcing the power off loses unsaved data and may corrupt active data transfers to storage.

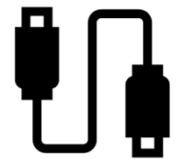

SOKKIA